



**JUSHUI**

**ISO9001 ISO14001**



**ART. - 1102**

**MS58 BRASS BALL VALVE**  
**FORGING OR CASTING BRASS BODY**  
**STEEL HANDLE WITH PLASTIC SLEEVE**  
**TEMPERATURE: -10 - +150°C**  
**PRESSURE: 25 BAR**  
**APPLICATION: WATER**

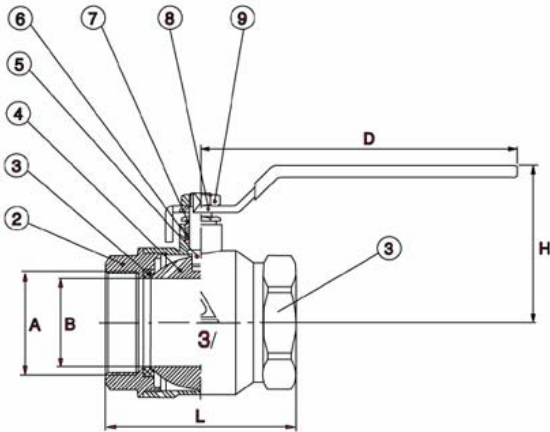

No.	Name	Material	Treatment
1	Body	Brass MS58	Nickel plated
2	Bonnet	Brass MS58	Nickel plated
3	Seat	PTFE	
4	Ball	Brass MS58	Chrome plated
5	Stem	Brass MS58	
6	Gasket	PTFE	
7	Press nut	Brass MS58	
8	Handle	STEEL	Chrome plated
9	Head Part	Brass MS58	Nickel plated

A	L	D	H	B
	43,8	89	37	10
1/2	47	101	40	14
3/4	53	101	43	18,5
1	65	112	56	23
1 1/4	73	132	62	29
1 1/2	81	132	67	37
2	98	161	91	47
2 1/2	136	225	113,5	64
3	151	225	119,5	75
4	180	225	149	97

	mm	Kv
3/8	10	15
1/2	14	17
3/4	18,5	35
1	23	49
1 1/4	29	86
1 1/2	37	151
2	47	230
2 1/2	64	450
3	75	700
4	97	1100

